



**INDUSTRIES LTD.**

***MODEL NT20 CONDENSATE NEUTRALIZATION TANK***

The NT20 is ideal for neutralizing condensate from condensing boilers or furnaces.

The condensate is acidic and has the potential to harm the environment and the sewer system. The NT20 will neutralize the condensate to a neutral pH level before it is discharged to drain.



**FEATURES and BENEFITS**

- *Neutralized condensate will not corrode drain and sewer systems*
- *Neutralized condensate will not harm the local environment*
- *Fast and easy installation*
- *Two inlets (top and side) make it easier to adapt to most appliance drains*
- *Made of only corrosion resistant materials*
- *Suitable for all types of condensing boilers and furnaces*
- *20 liter (5.3 US gallon) tank for complete neutralization*
- *Available with or without initial charge of neutralizing agent*
- *Suitable for appliance sizes up to 3.0 MBTU*

Represented By:

**AXIOM INDUSTRIES LIMITED** 2615 WENTZ AVENUE SASKATOON, SK S7K 5J1  
**TOLL FREE :** (877) 651-1815 **PHONE :** (306) 651-1815 **FAX :** (306) 242-3373

**www.axiomind.com**



**INDUSTRIES LIMITED**

**NT20 CONDENSATE NEUTRALIZATION TANK  
TECHNICAL INFORMATION**

**WEIGHT** - 2 kg, 4.4 lbs. (empty)

**SPECIFICATION**

The condensate neutralization tank shall be AXIOM INDUSTRIES LTD. Model NT20. System shall include 20 litre (5.3 U.S. gallon) tank made from one-piece seamless polyethylene construction with 125-mm (5") fill/access opening, 1-1/2" FIP inlets on the top and the side, 1-1/2" FIP side outlet, and 1-1/2" FIP top vent.

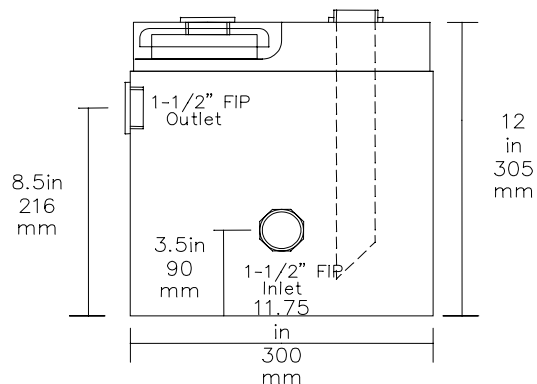
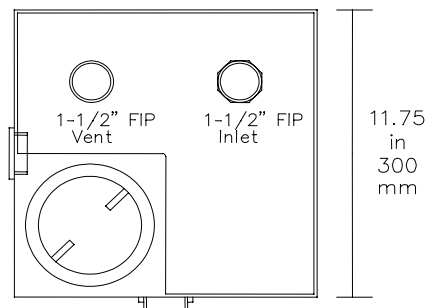

Clearances - Top and Left Side -  
12 in 305 mm

**ACCESSORIES**

- SMW-003** – Tank Mounting Shelf
- GRM000** – 40 lbs. Of limestone chips (Recommended amount for NT20)

Project \_\_\_\_\_  
 Consultant \_\_\_\_\_  
 Unit Tag \_\_\_\_\_

Location \_\_\_\_\_  
 Contractor \_\_\_\_\_  
 Sales Agent \_\_\_\_\_